

07 / 2019

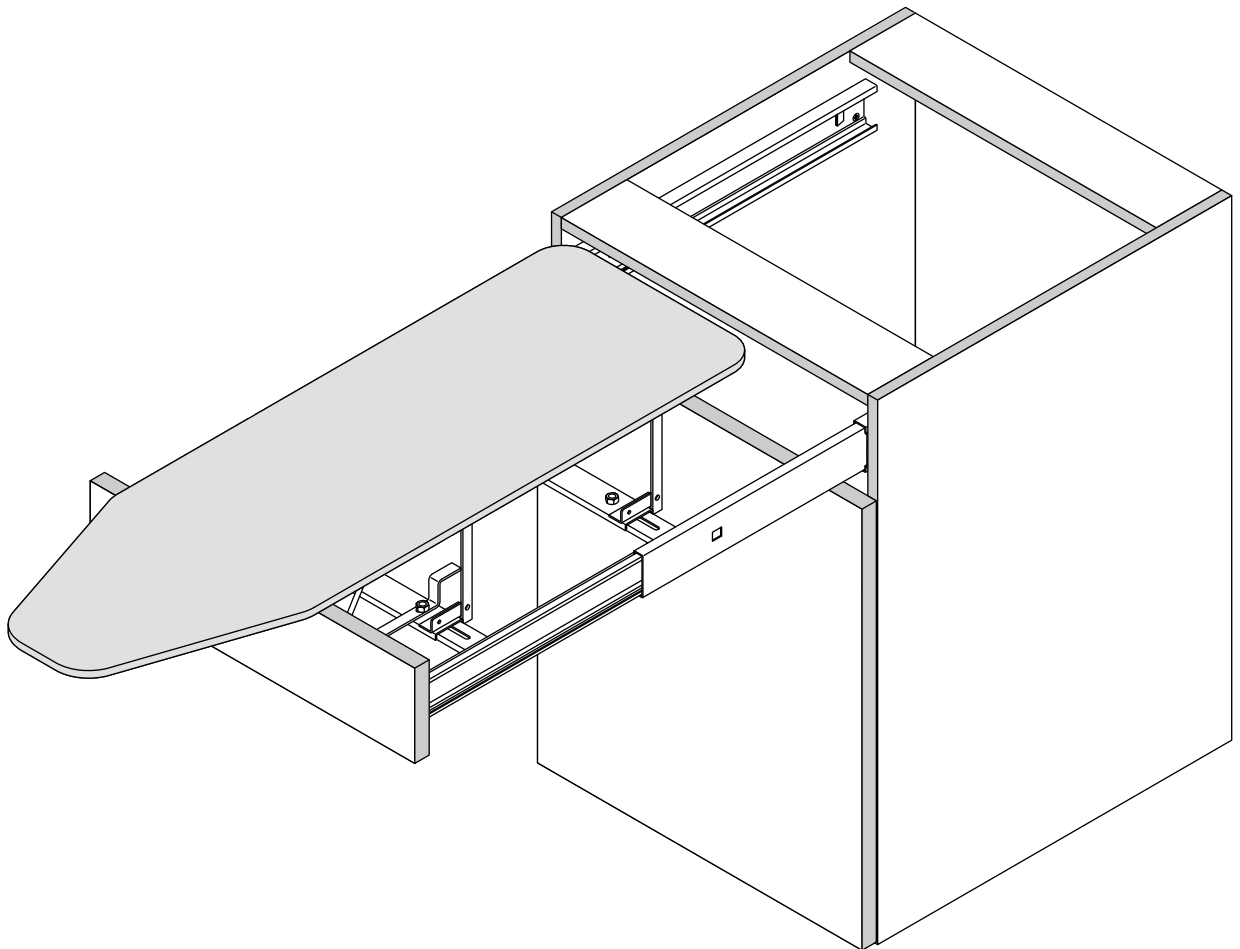

# VS ADD<sup>®</sup> Iron

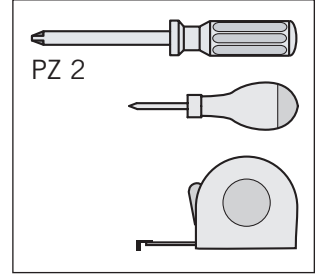
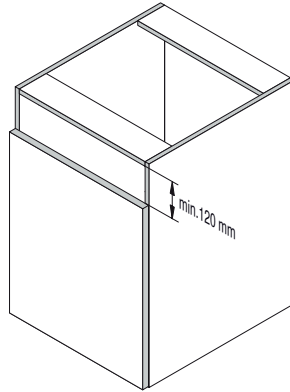
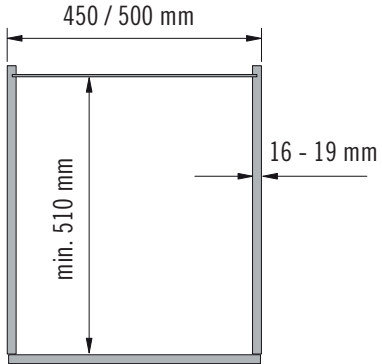

### 1 Montage Korpussschienen Führungen „links / rechts“

Die Führungen sind so zu positionieren, dass zwischen Korpusvorderkante bis Mitte Anschraubloch (Führung) 34 mm entstehen und von Korpusoberkante bis Mitte Anschraubloch 74 mm bei einer Arbeitsplattenstärke von 30 mm (Arbeitsplattenstärke 40 mm = 64 mm) entsteht (siehe Ansicht A).

**Befestigungsmaterial:**

Euroschrauben 6.3 x 13  
oder  
Senkkopfschrauben 4.5 x 15

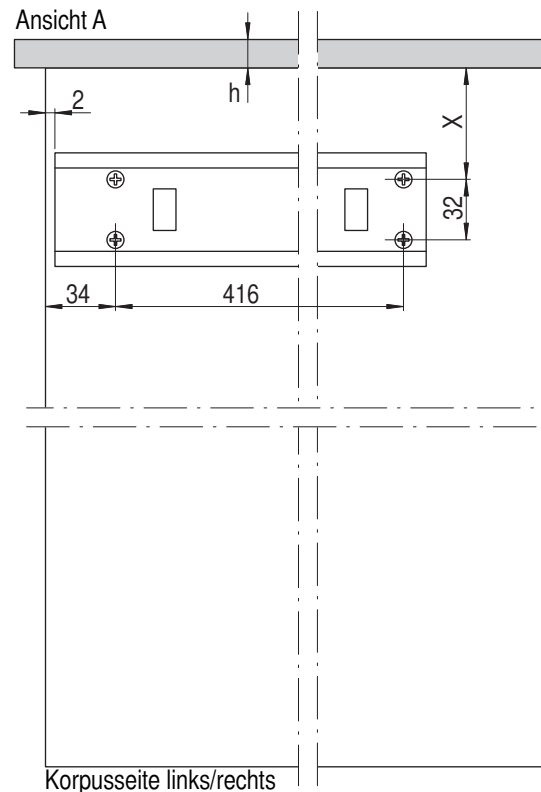
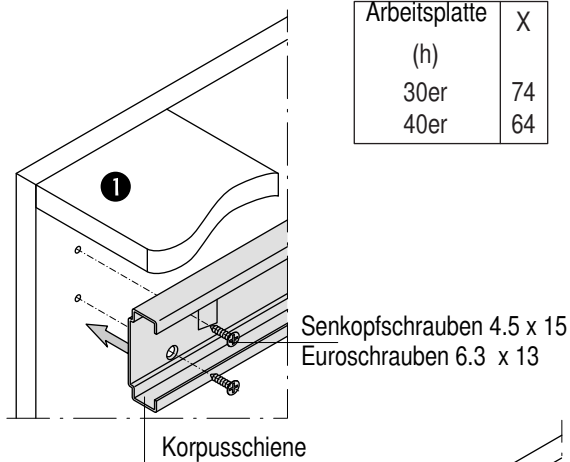

### 2 Montage Führungsschiene „links und rechts“

Führungsschiene mit Träger über den Anschlag der Korpussschiene schieben.

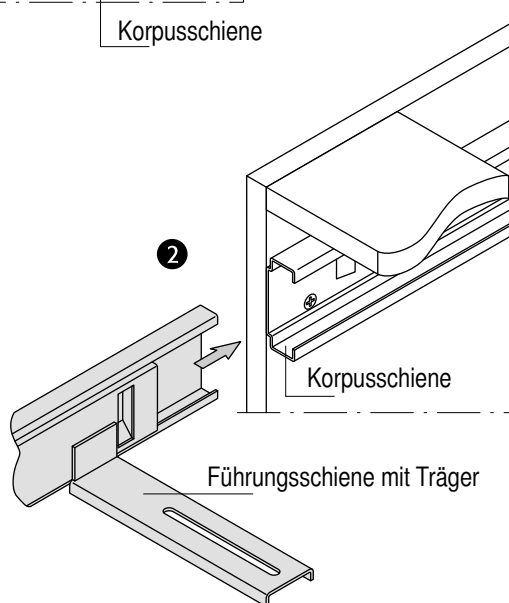

### 3 Montage Bügel auf den Träger

Das Bügelbrett wird nun mittig auf den Träger aufgesetzt. Den Stützwinkel dann auf den vorderen Träger stellen. Nun Bügelbrett und Stützwinkel mit dem Träger vorne und hinten von unten verschrauben.

**Befestigungsmaterial:**

Zylinderkopfschrauben M 6.0  
Unterlegscheibe  
Mutter M 6.0

**Achtung:**

Auf leichten Lauf der Schiene achten, bevor die Schrauben festgezogen werden.

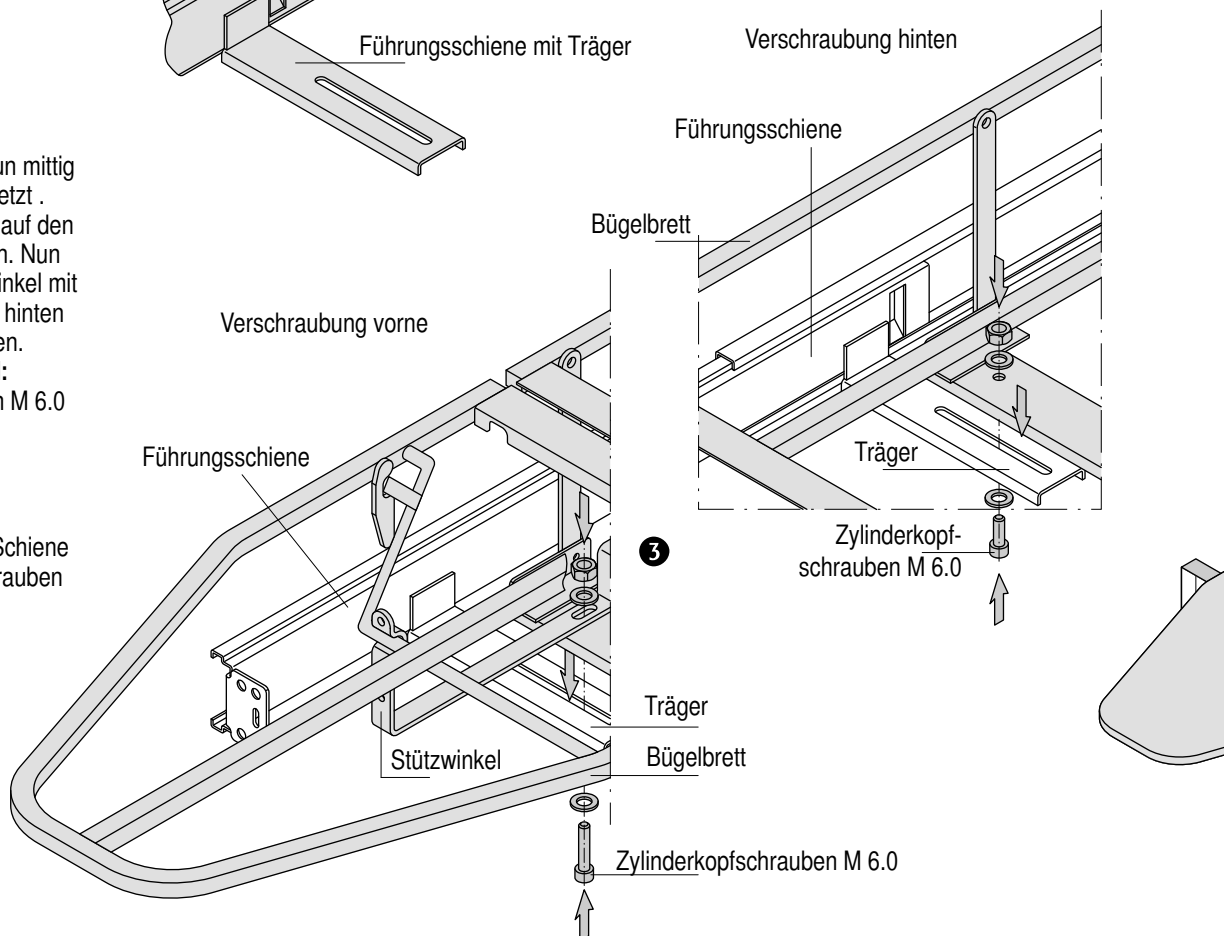

Ansicht B

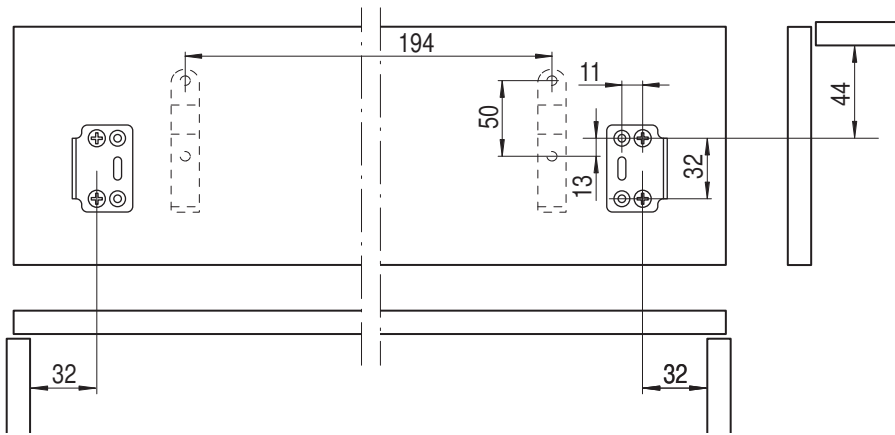

#### 4 Montage „Frontblende“

Die Blende an der Führungsschiene wie Bohrbild verschrauben (siehe Ansicht B).

**Befestigungsmaterial:**

Euroschrauben 6.3 x 13

oder

Senkkopfschrauben 4.5 x 15

#### 5 Montage Stützwinkel mit Bügel an der Blende

Den Stützwinkel mit der Front verschrauben.

**Befestigungsmaterial:**

Panhead-Schrauben 4.0 x 15

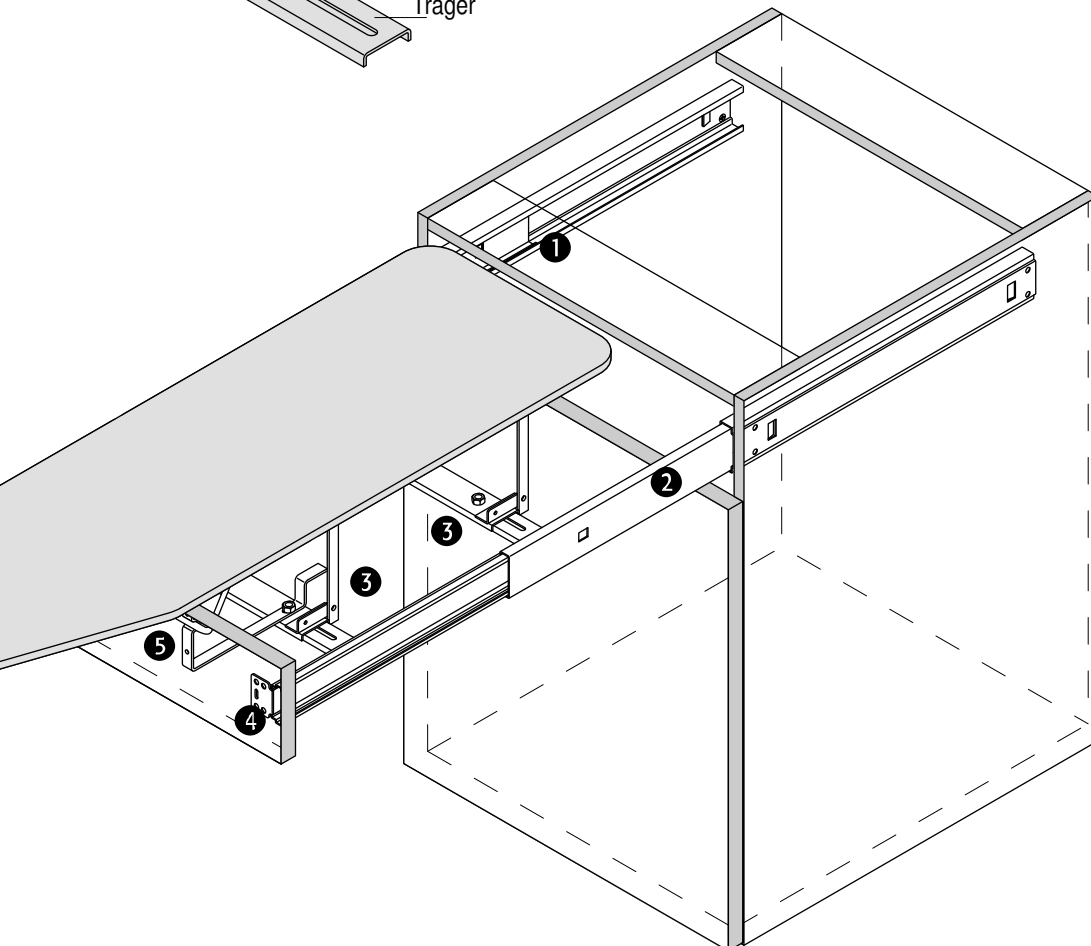
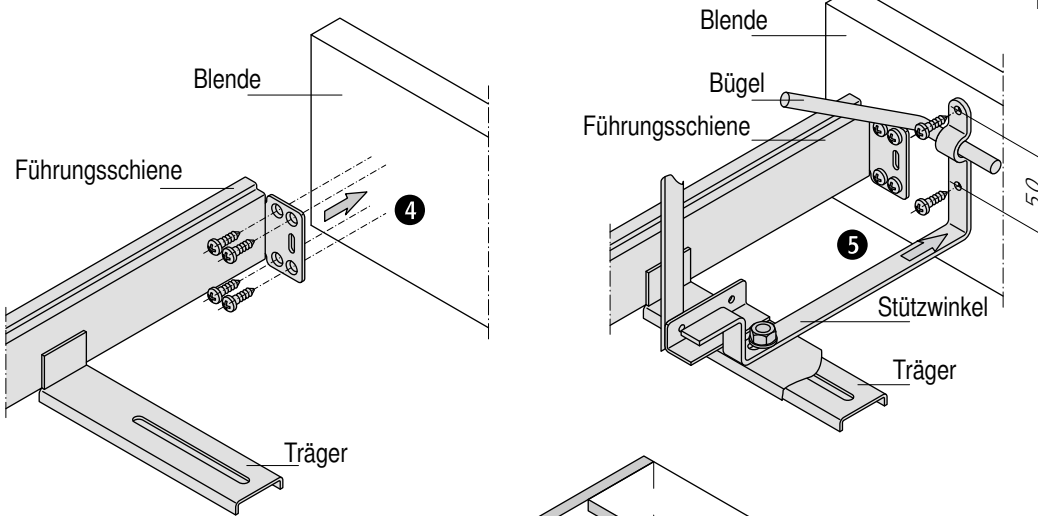



07 / 2019



# VS ADD<sup>®</sup> Iron

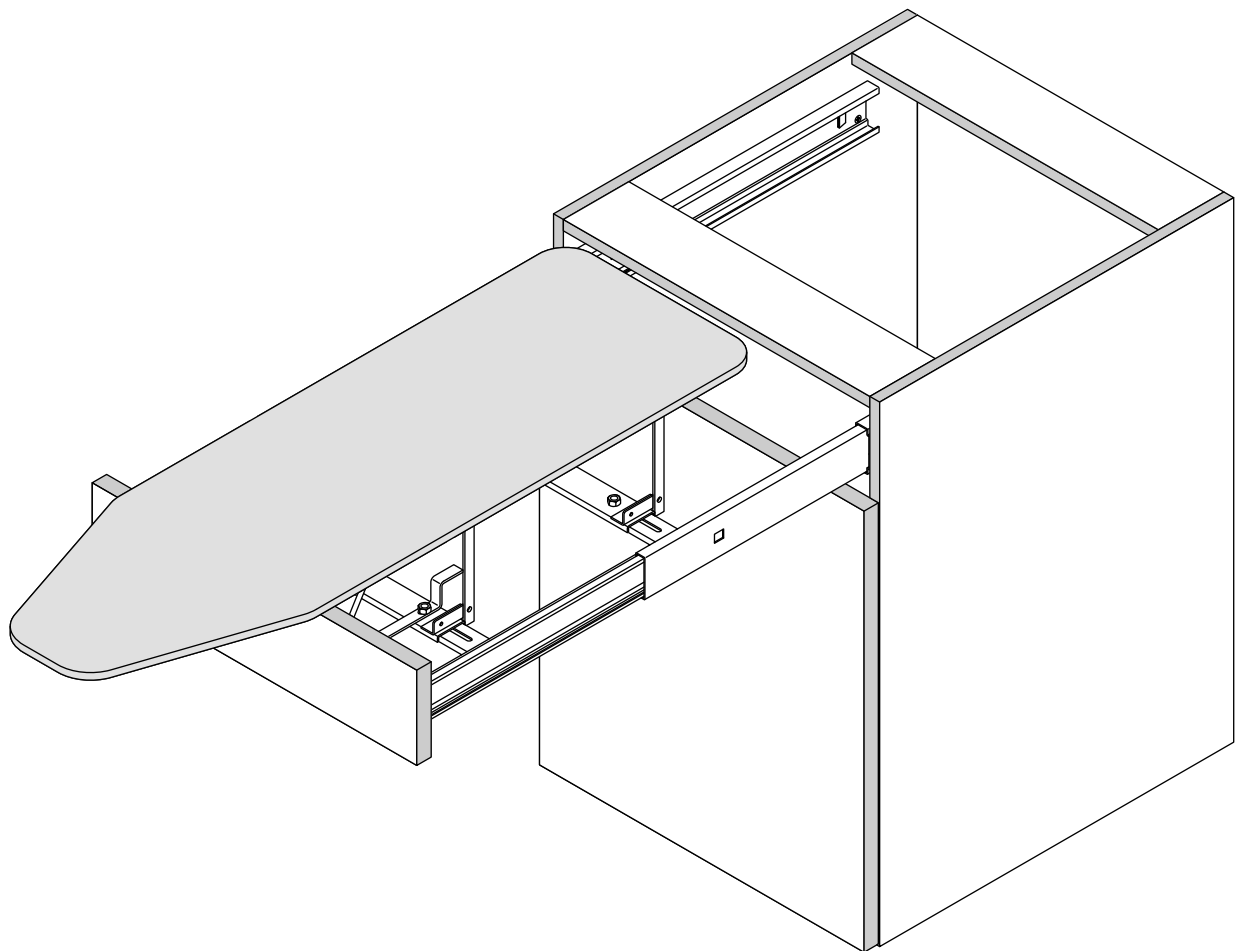
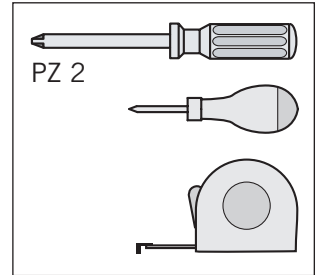
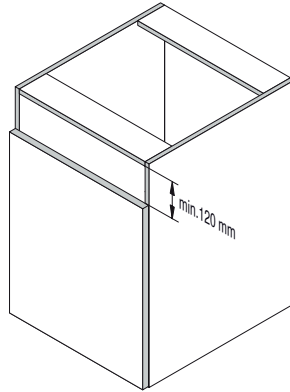
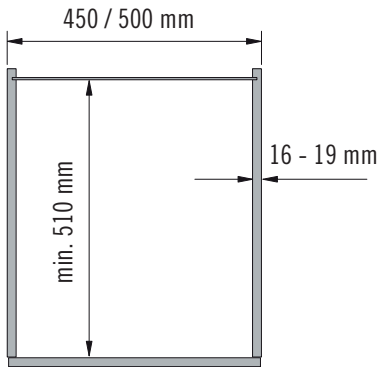

### 1 Assembling the cabinet guide slide "left / right"

The guide slides are to be positioned in such a way that there are 34 mm between the cabinet front edge and the middle hole of the slide; and from the cabinet upper edge to the middle hole of the slides, there should be 74 mm with a work area stength of 30 mm (work plate area 40 mm = 64 mm) (see diagram A).

**Fasteners:**

countersunk screws 4.5 x 15  
or Euro-screws 6.3 x 13

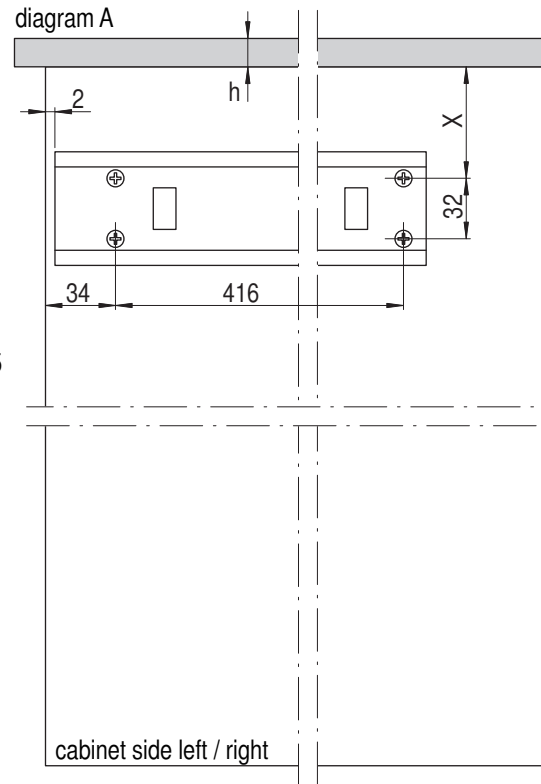
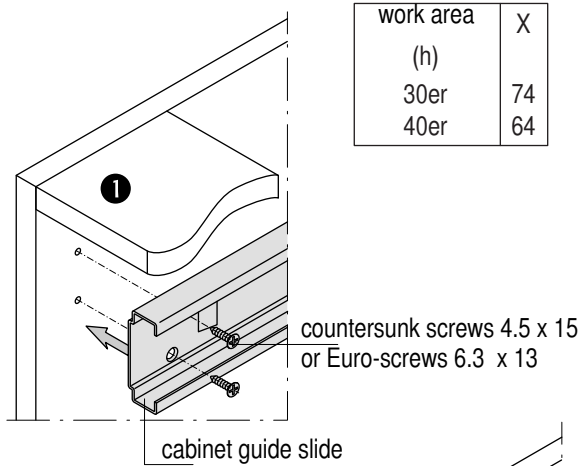

### 2 Assembling guide slide "left / right"

Push the guide with the support bracket across the mounted cabinet slide.

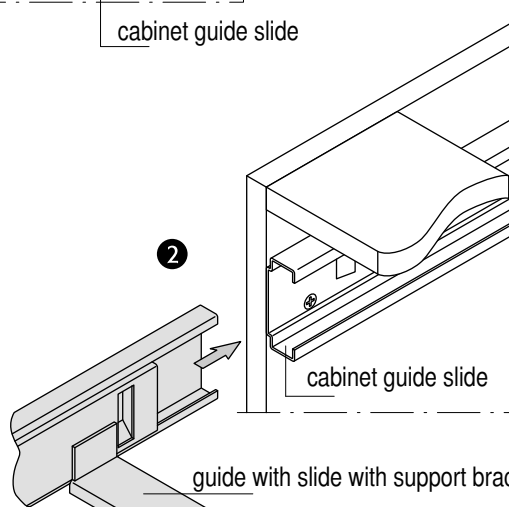

### 3 Assembling Ironing Board on the Support Bracket

The board is placed in the middle of the support bracket. Place the angle support on the front support bracket. Screw the Ironing board and the angle support bracket from underneath on the support bracket in the front and back.

**Fasteners:**

Cylinder head screws M 6.0  
Washers  
Screw nut M 6.0

**Note:**

Make sure the slide movement is smooth before firmly tightening all screws.

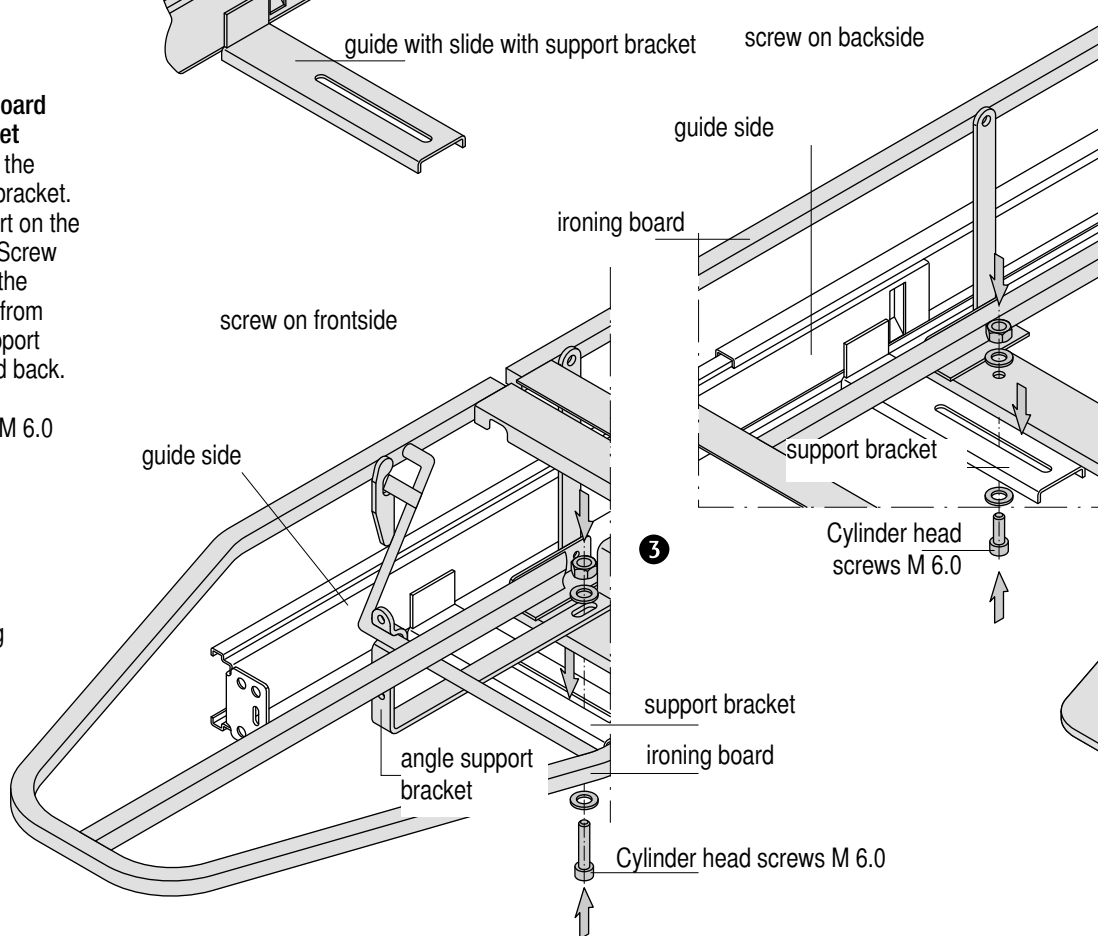
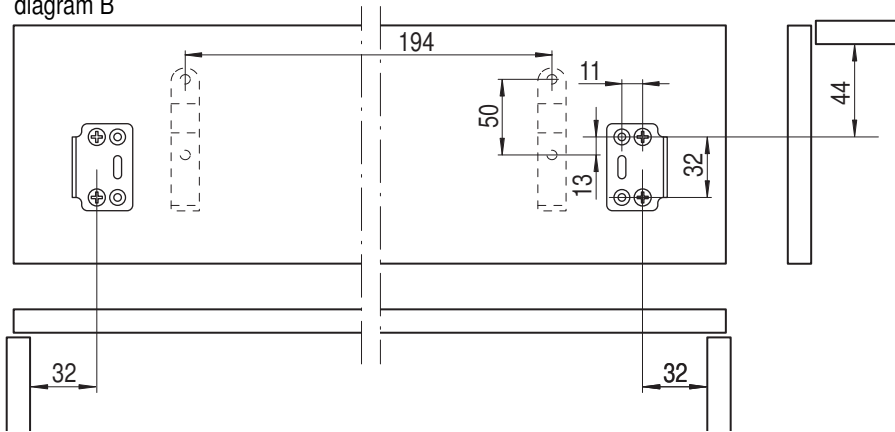

diagram B



**4** Assembling “frontis plate”  
Attach the “frontis plate” as indicated in diagram B.

**Fasteners:**  
countersunk screws 4.5 x 15  
or Euro-screws 6.3 x 13

**5** Assembling angle support  
bracket with the board to  
the frontis plate:

screw the angle support  
bracket onto the frontis plate.  
**Fasteners:**  
panhead screws 4.0 x 16

